

Agricultural Lubrication solutions

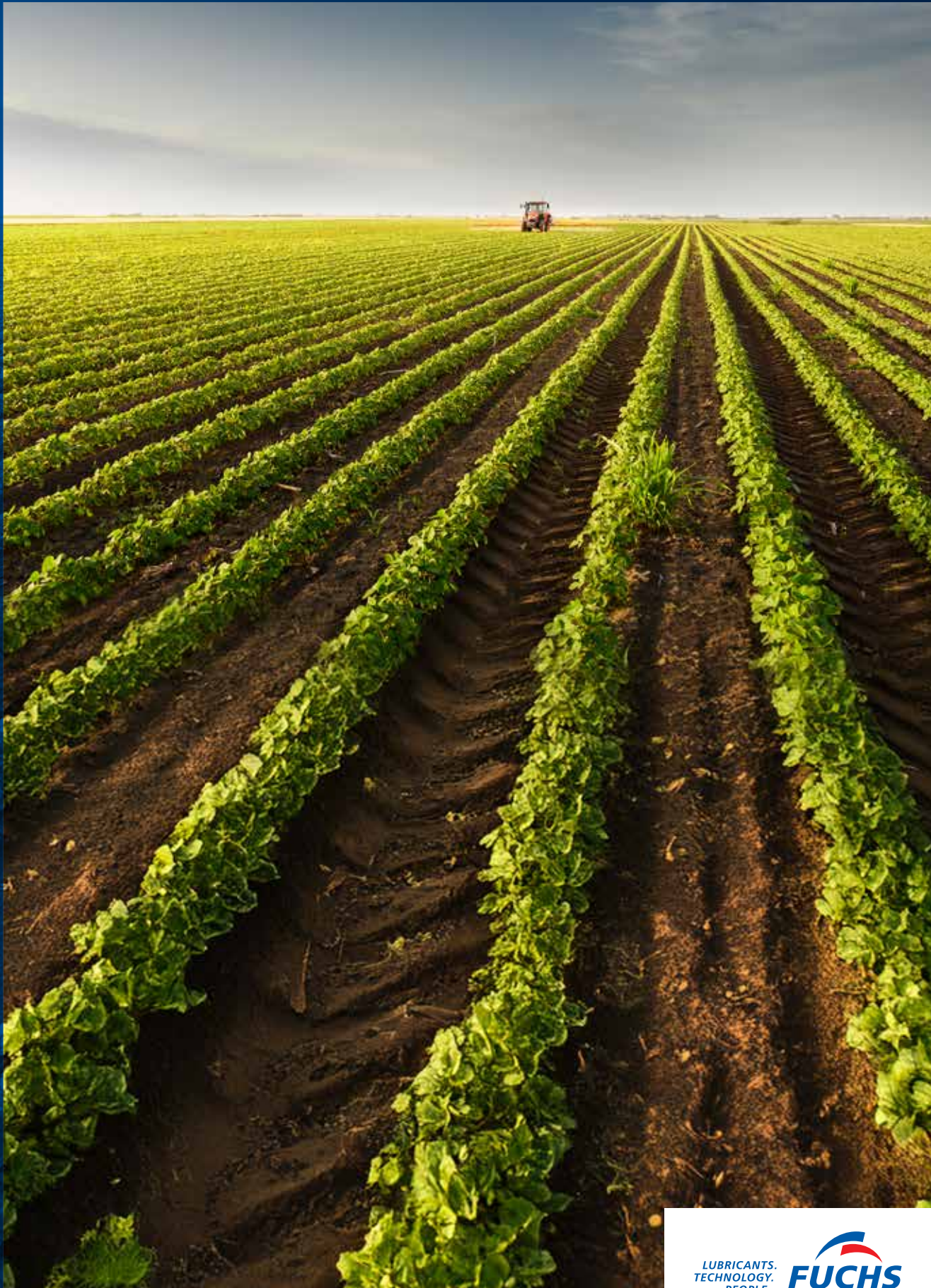

MOVING YOUR WORLD



FUCHS LUBRICANTS SOUTH AFRICA

We don't just develop lubricants for highly complex challenges in a wide range of industries, we develop innovative lubricant solutions that enable the mobility of tomorrow. Our goal: to keep our customers' world in motion. Efficient, sustainable, reliable. Today and tomorrow.

What can we move for you?

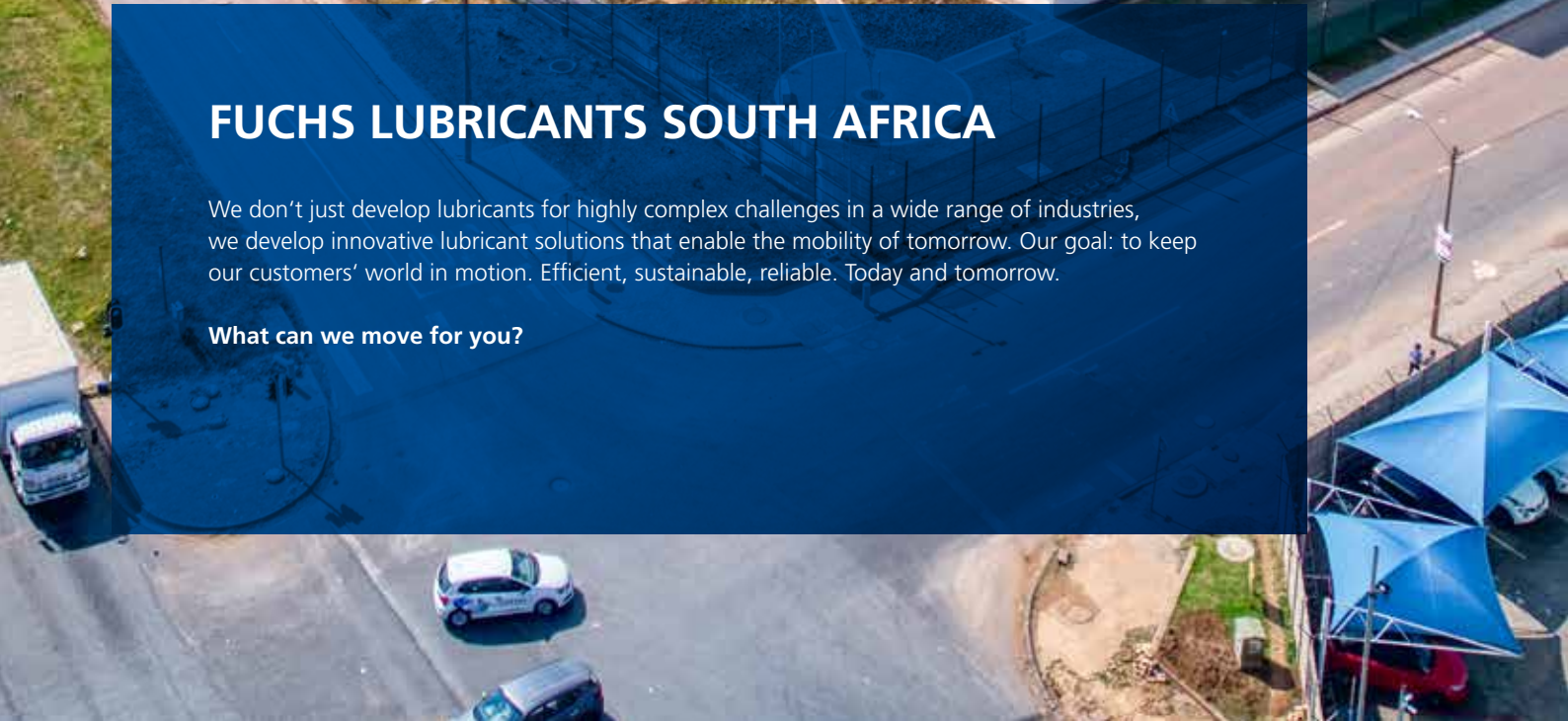



FUCHS LUBRICANTS SOUTH AFRICA

Facts and figures

Company: FUCHS LUBRICANTS SOUTH AFRICA, A COMPANY OF THE FUCHS GROUP

Headquarters: Johannesburg, Gauteng

Product range: A full range of more than 2,000 products and 6,000 articles

Certifications: IATF 16949, ISO 9001, ISO 14001, ISO 45001, ISO 50001

Since 1931, we have been pursuing the same goal: to keep the world moving. With innovative and technological lubricant solutions that have a sustainable impact on the future. Unconditional reliability is our top priority, it is the foundation of our company and basis for everything that defines us.

Reliability is both a driver and a demand. And it's a promise to all our customers in the fields of automotive suppliers and OEMs, mechanical engineering, metal processing, mining and exploration, aerospace, energy, construction and transport, agriculture and forestry, as well as the paper, steel, metal, cement, forging and food industries, but also qualified lubricant dealers, car dealerships and workshops.

Long-term experience, high development strength and the fulfillment of far-reaching standards are the basis for the special quality of our world-leading product brands. We deliver solutions that are simply more efficient and therefore more sustainable. We always think in holistic solutions. For the development of individual solutions, we enter into an intensive customer dialog with you. This is the way we live up to our claim of moving your world.

MOVING YOUR WORLD



AGRIFARM

SAFETY IS OUR STRENGTH

FUCHS has been active in the agricultural lubricant market for more than 70 years, both as an OEM for machine manufacturers and in the field of workshop services. The latest innovative lubricants under the AGRIFARM brand secure maximum operational reliability of all agricultural units – from engines and transmissions, right through to hydraulics in all machines and vehicles. AGRIFARM lubricants have proved extremely successful even under the very toughest conditions and thereby offer the highest level of reliability for your vehicle fleet.

Safety during application

AGRIFARM lubricants have proved extremely successful even under the very toughest conditions and thereby offer the highest level of reliability for your vehicle fleet.

AGRIFARM will make the difference for you

AGRIFARM products are lubricants of the very highest quality made by FUCHS, which meet the latest standards of leading manufacturers in terms of application safety. FUCHS only uses selected base oils and specially developed additives for the manufacturing of AGRIFARM lubricants.

Our expertise guarantees the greatest reliability. AGRIFARM is the worldwide specialist for high-end lubricants

Agricultural machines must deliver top performance on a daily basis. As a professional, you know how decisive the right oil is for the performance and durability of such a machine. So place your trust in the FUCHS AGRIFARM range of high-tech lubricants.

Noticeably increased oil change intervals in engines and significantly fewer signs of wear are just some of the visible results.

Special lubricants for agriculture

Alongside lubricants that can only be used for a certain component there are also the all-rounders: the STOU and UTTO products that come into use in agricultural applications.

Both were developed for use in transmission and hydraulic systems and can also be deployed in brakes designed to run in an oil bath (wet brakes).

STOU products can also be used in an engine if the respective specifications are met. In other words, a STOU is an UTTO with engine performance. An overview is provided in the table below.

Aggregate	UTTO*	STOU**
Engine (with or without turbocharging)		X
Manual gearboxes	X	X
Gearboxes and gearbox-hydraulic systems with or without integrated wet brakes	X	X
Hydraulic systems	X	X
Final drives	X	X

*UTTO = Universal Tractor Transmission Oil

**STOU = Special Tractor Oil Universal











Limited Slip (LS)

LS lubricants are gear oils for differentials with disc lock, which guarantee perfect functionality and low noise under all loads.

Package overview

NEW!

Get a quick overview of the available packages of a product. Under each product pictograms and package units are listed accordingly.

	Bottle		Cartridge
	Canister		Tub
	1000 L (IBC FB)		Spray can
	Drums		Bucket
	Tanker		50kg

FUCHS AGRIFARM makes all the difference

The highest quality and the largest selection – guaranteed

With a broad portfolio of specially developed lubricant solutions, FUCHS AGRIFARM offers optimal all-round protection for your machines.

STOU

AGRIFARM STOU SAE 15W-40

Engine

TITAN TRUCK PLUS SAE 15W-40
TITAN CARGO SAE 15W-40

Coolant

FRICOFIN DP
FRICOFIN DP 50
FRICOFIN LL 50
FRICOFIN JF
FRICOFIN JF 50

Grease points

RENOLIT M0/2/3
RENOLIT LUBRENE LX 220 EP 2
RENOLIT LUBRENE LXCA 700 EP2
RENOLIT LCWP 1/2
RENOLIT GCR SPRAY
RENOLIT FLM 2
RENOLIT LUBRENE LIM 450 EP 1/2
RENOLIT ANTISEIZE PMP



Cleaner

FUCHS Bio Clean
RENOCLEAN BIO HD

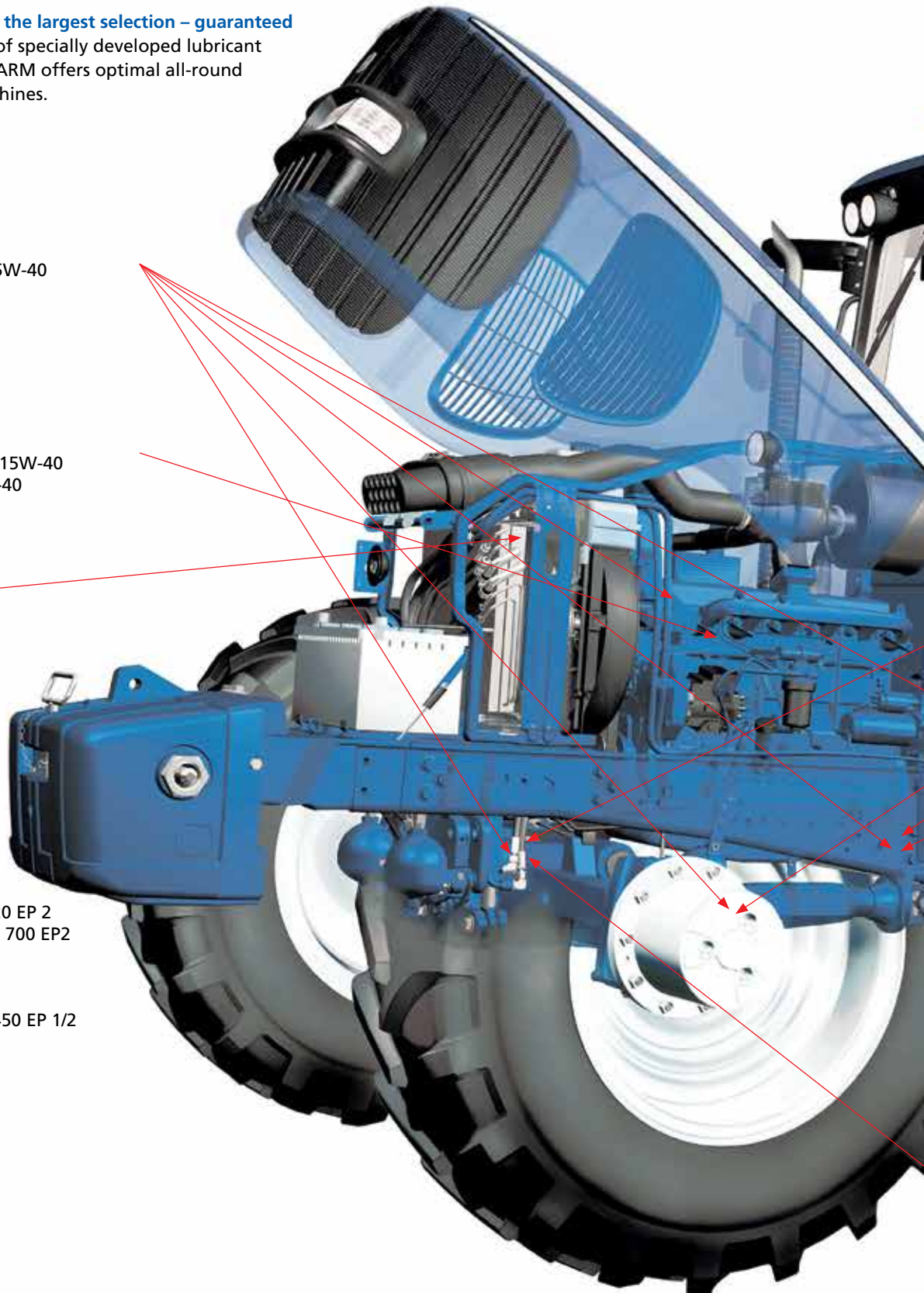

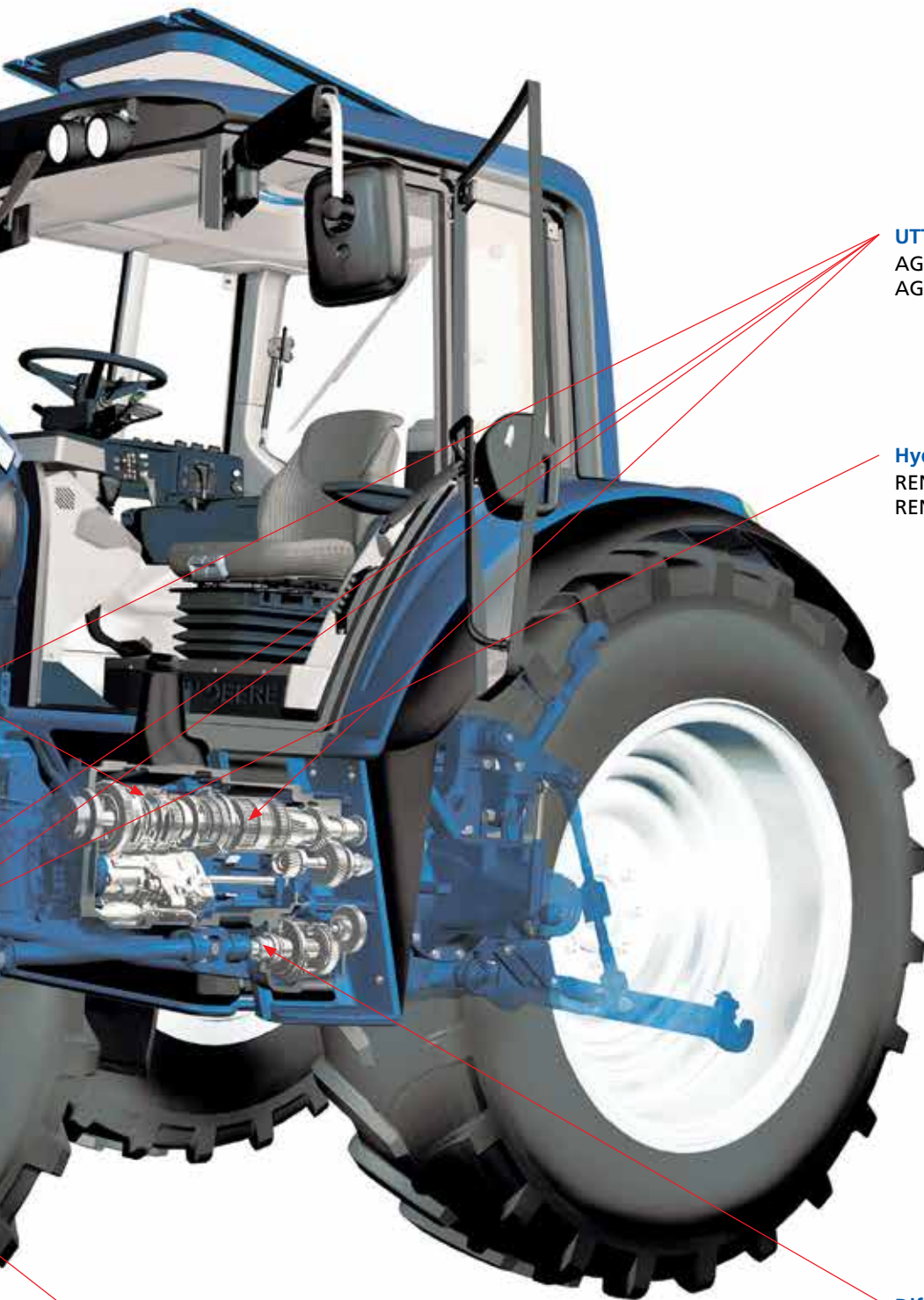
**UTTO**

AGRIFARM UTTO MP
AGRIFARM UTTO FLEX

Hydraulic

RENOLIN HO 46/68/100 (ZINC FREE)
RENOLIN B 68 PLUS (ZINC CONTAINING)





Gearbox

TITAN SUPERGEAR SAE 80W-90
TITAN SUPERGEAR LS SAE 80W-90

Diff

TITAN SUPERGEAR SAE 80W-90
TITAN SUPERGEAR LS SAE 85W-140



















Multifunctional Oils

Product name	Description	Specifications	Approvals	FUCHS Recommendations
UTTO Oils for Agricultural Machinery				
AGRIFARM UTTO MP	Ultra High Performance Multifunctional Oil (UTTO/MFO) for use in transmission and hydraulic systems with integrated wet brakes, clutches and differentials for agricultural and construction machinery.	API GL-4	DANA-OHTM-UTTO VALTRA G2-08 VOLVO WB 101 ZF TE-ML 03E, 05F, 06K, 17E, 21F (ZF002183)	AGCO Powerfluid 821 XL AGCO Q-186 (Whitefarm) ALLISON C-4 CASE MS 1230, 1210, 1209, 1207, 1206 CAT TO-2 CLAAS / LANDINI / SAME-Transmission CNH MAT 3505, 3506, 3509, 3525, 3526, 3540 DIN 51524 : HLP (-D) FNHA-2-C-200.00 / -201.00 FORD M2C48-C3, ESN M2C86-B/C, M2C134-D JOHN DEERE JDM J20C KUBOTA UDT FLUID MASSEY FERGUSON CMS M 1145, 1143, 1141, 1135 NH 410C, 410B SAE J300: 10W-30 SAE J306: 75W-80 SDFG OT 1891 A VALTRA G2-B10
	5 L (Bottle), 20 L (Canister), 210 L (Drum), 1000 L (IBC FB), Tanker			
AGRIFARM UTTO FLEX	Multifunctional Oil (MFO) designed for transmissions, final drives, hydraulics and oil immersed brakes of agricultural and certain off-highway equipment.	API GL-4	-	ALLISON C-4 CASE MS 1209, 1207, 1206 CAT TO-2 CNH MAT 3525, 3526 FORD ESN M2C86-B/C FORD M2C134-D JOHN DEERE JDM J20C MASSEY FERGUSON CMS M 1145, 1143, 1135 VOLVO WB 101
	5 L (Bottle), 20 L (Canister), 210 L (Drum), 1000 L (IBC FB)			
AGRIFARM STOU SAE 15W-40	High Performance Multifunctional Oil (STOU / MFO) for engines, manual gearboxes, wet brakes, hydraulics in tractors and other agricultural equipment.	API GL-4	FENDT KDM 17/2012	ACEA E2 API CF-4 CNH MAT 3525, 3526 DIN 51524 : HLP (-D) FNHA 200.00, 201.00 FORD M2C134-D, M2C159-B/C JOHN DEERE JDM J20C MASSEY FERGUSON CMS M 1145, 1144, 1143, 1139, 1135 NEW HOLLAND 82009201/2/3 NH 420A SAE J306: 80W-90 SDFG OU 1391, OT 1891 STEYR D-401 ZF TE-ML 06A, 06B, 06C, 07B
	5 L (Bottle), 20 L (Canister), 210 L (Drum), 1000 L (IBC FB), Tanker			
Agricultural Engine Oils				
TITAN 2T TC	TITAN 2T TC is a specially formulated, self-mixing 2- stroke engine oil designed to meet the demands of modern two-stroke engines.		API TC	-
	200 ML (Bottle), 500 ML (Bottle), 5 L (Bottle), 20 L (Canister), 210 L (Drum), 1000 L (IBC FB)			
TITAN 2T PLUS	TITAN 2T PLUS is a specially formulated semisynthetic, self-mixing 2-stroke engine oil designed to meet the demands of modern two-stroke engines.		-	-
	1 L (Bottle), 5 L (Bottle), 20 L (Canister), 210 L (Drum), 1000 L (IBC FB)			

* Import on request

Performance upgrades in Specifications, Approvals and FUCHS Recommendations are highlighted in bold.

AGRIFARM

Product name	Description	Specifications	Approvals	FUCHS Recommendations
Agricultural Engine Oils				
TITAN 2T 100S	Ultra-High Performance two-stroke engine oil for Auto lube and Premix systems formulated with fully synthetic base oils.	API TC JASO FD ISO L-EGD	-	TISI
	1 L (Bottle)			
TITAN TRUCK PLUS SAE 15W-40	Ultra High Performance Engine Oil for a variety of diesel and petrol engines. Specially for highly-loaded commercial vehicle diesel engines. Low oil consumption.	ACEA E7 API CI-4/SL GLOBAL DHD-1 CAT ECF-1-a/ ECF-2	CUMMINS CES 20076/7/8 DETROIT DIESEL 93K215 DEUTZ DQC III-18 DFTR 15B110 (MB 228.3) MACK EO-N MTU DDC TYPE 2 RENAULT RLD/RLD-2 VOLVO VDS-3	ALLISON C-4 CAT TO-2 CASE MS 1121 CUMMINS CES 20071/2 IVECO 18-1804 CLASSE T2 E7 MAN M 3275-1 NH 330H
      	500 ML (Bottle), 1 L (Bottle), 5 L (Bottle), 20 L (Canister), 210 L (Drum), 1000 L (IBC FB), Tanker			
TITAN CARGO SAE 15W-40	Premium Performance, fuel-economy engine oil for a variety of commercial vehicle diesel engines. Specially developed for vehicles with extended service intervals, exhaust after treatment and turbocharger.	ACEA E11/E7 API CK-4/CJ-4/ SN CAT ECF-3 JASO DH-2	ALLISON TES-439 (439-34862020) CUMMINS CES 20086 DETROIT DIESEL 93K222 DEUTZ DQC III-18 LA DTFR 15C100 (MB 228.31) FORD M2C171-F1 MACK EOS-4.5 MAN M 3775 MTU DDC TYPE 2.1 RENAULT RLD-3 VOLVO VDS-4.5	ACEA E9 MAN M 3575 RENAULT RLD-4
    	5 L (Bottle), 20 L (Canister), 210 L (Drum), 1000 L (IBC FB)			
TITAN CARGO FLEX LD SAE 10W-40	Premium Performance engine oil with outstanding fuel-economy properties for highly supercharged gas-powered commercial vehicle engines as well as diesel engines with exhaust gas after treatment systems. Optimum cold starting, reduced oil consumption, and minimised exhaust emissions.	API CK-4/SN CAT ECF-3 JASO DH-2 ACEA E11, E8, E7	DEUTZ DQC IV-18 LA DTFR 15C100 (MB 228.31) DTFR 15C110 (MB 228.51) MACK EOS-4.5 MAN M 3775 MTU DDC TYPE 3.1 RENAULT RLD-3 VOLVO VDS-4.5	ACEA E9, E6 CUMMINS CES 20086 DETROIT DIESEL 93K222 IVECO 18-1804 CLASSE TLS E9 MAN M 3477 MAN M 3575 RENAULT RLD-4 SCANIA LA
  	20 L (Canister), 210 L (Drum), 1000 L (IBC FB)			
TITAN CARGO MAXX II SAE 5W-30	Premium MAXX Performance Engine Oil with new XTL-Technology. Specially developed for vehicles with modern exhaust after treatment and turbocharger. Optimum cold starting properties and ageing stability for extreme fuel-economy over the whole draininterval	ACEA E11, E8, E7, E4 API CK-4/CJ-4 CAT ECF-3 JASO DH-1/ DH-2/DL-0	CUMMINS CES 20081 CUMMINS CES 20086 DETROIT DIESEL 93K222 DEUTZ DQC IV-18 LA DTFR 15C100 (MB 228.31) DTFR 15C110 (MB 228.51) DTFR 15C120 (MB 228.52) MACK EOS-4.5 MAN M 3677 MAN M 3775 MAN M 3777 MTU DDC TYPE 2.1 MTU DDC TYPE 3.1 RENAULT RLD-3 SCANIA LDF-4 VOLVO VDS-4.5	ACEA E9, E6 DAF PSQL 2.1E-LD DETROIT DIESEL 93K218 IVECO 18-1804 CLASSE TLS E6 LIEBHERR LH-00-ENG LA MAN M 3271-1 MAN M 3477 MAN M 3575 RENAULT RLD-4 SCANIA LA
 	20 L (Canister), 1000 L (IBC FB)			



















RENOLIT LUBRICATING GREASES FOR YOUR UNITS

Lubricating greases are consistent lubricants made up of base oil and a specially chosen thickener. To increase certain properties, additives are added to the lubricating greases.

Lubricating greases are structural elements, especially when used as long-life lubricants for lifetime lubrication.















RENOLIT lubricating greases are a balanced and complete package offering the ideal technical and economical solution in the largest possible number of lubricating grease applications in agriculture.

RENOLIT









Product name	Thickener Base oil	Solid lubricants	NLGI grade	Base oil viscosity at 40 °C [mm ² /s]	Main application area
Greases					
RENOLIT LC-WP 1/2	Lithium Calcium	N	1/2	1000	Extreme pressure (EP), water resistant grease for low-speed roller element or plain bearings.
  	500 G (Tub), 15 KG (Drum), 18 KG (Bucket), 50 KG (Drum), 180 KG (Drum)				
RENOLIT GC-R SPRAY	Inorganic	Y	N/A	>300	Solid containing grease spray Gear, chain and rope spray.
	350 ML (Spray can)				
RENOLIT FLM 2	Lithium	Y	2	100	Multipurpose grease with MoS ₂ Extreme pressure (EP) grease for low to medium speed roller element or plain bearings where shock loads are experienced.
  	500g Tub, 5 KG (Bucket), 18 KG (Drum), 50 KG (Drum), 180 KG (Drum)				
RENOLIT LUBRENE LIM 450 EP 1/2	Lithium Calcium	Y	1/2	450	High performing Heavy duty multipurpose grease with MoS ₂ . Medium to high loaded plain and roller bearings operating at low to medium speeds.
 	5 KG (Bucket), 18 KG (Drum), 180 KG (Drum)				
RENOLIT M0/2/3	Lithium	N	0/2/3	250	Multipurpose grease with good corrosion protection. Extreme pressure (EP) grease for medium to high speed roller element or plain bearings.
 	Cartridge, Tin, Bucket, 180 KG (Drum)				
RENOLIT LUBRENE LX 220 EP 2	Lithium	N	2	220	All types of hydraulic systems including gear, piston and vane type pumps. For most general industrial bearing and circulating oil systems which do not require oil with extreme pressure properties.
 	Cartridge, Tin, Bucket, 180 KG (Drum)				
RENOLIT ANTI-SEIZE PMP	Inorganic	Y	1	>500	Aluminium based anti-seize paste Nuts ,screws and bolts, steam pipe threads, boiler gaskets, drilling rod threads.
 	500 G (Tub), 5 KG (Bucket), 18 KG (Bucket), 50 KG (Drum), 200 KG (Drum)				
CASSIDA FM GREASE MP 2	Aluminium Complex	N	2	180	Food grade multipurpose grease. Certifications: NSF, H1 NSF ISO 21469 HALAL KOSHER
	17 KG (Drum), 180 KG (Drum)				







Industrial and Miscellaneous

Category	Product name	Description	Specifications	Approvals	Kin. visc. at 40 °C mm ² /s	Kin. visc. at 100 °C mm ² /s	VI	Pour-point °C	Main application area
Miscellaneous									
Hydraulic	RENOLIN HO RANGE	Hydraulic oils, based on carefully selected virgin base oils. Contains additives for excellent ageing and oxidation stability, the zinc-containing AW/EP additive system protects against wear at high pressure and load. Extended oil drain intervals are possible.	ISO 6743-4: HL; ISO 6743-6; ISO 12925-1: CKB; DIN 51524-1: HL	-	-	-	-	-	-
		20 L (Canister), 210 L (Drum), 1000 L (IBC FB)							
Hydraulic	RENOLIN B Plus Range	Hydraulic oils, based on high-quality, hydrotreated base oils group II. Contains additives for excellent ageing and oxidation stability, zinc-containing AW/EP additive system protects against wear at high pressure and load. Extended oil drain intervals are possible.	DIN 51524-2: HLP; ISO 6743-4: HM; Vickers vane pump	Denison HF-0, HF-1, HF-2; Bosch Rexroth RDE 90245	68	9	108	-33	-
		20 L (Canister), 210 L (Drum), 1000 L (IBC FB)							
Gear Oil	RENOLIN CLP 1000	High-performance gear and circulating oils with good ageing stability and additives to improve corrosion protection (also combat steel and non-ferrous metal corrosion caused by moisture). Outstanding antiwear characteristics – good EP / AW performance, excellent scuffing load carrying capacity and protection against micropitting, excellent FE8 roller bearing wear protection, good demulsifying properties, very good foaming behaviour.	DIN 51517-3: CLP, ISO 6743-6, 12925-1: CKC & CKD, CKSMP, AIST 224, AGMA 9005/E02:EP, David Brown S1 53.101	-	1000	51	90	-	Recommended for gear sets working under heavy load or shock load where lubricants of the CLP type according to DIN 51517-3 are recommended by the gear manufacturer. This product meets and, in many cases, exceeds the new requirements of well-known gearbox and bearing manufacturers.
		5 L (Bottle), 20 L (Canister), 210 L (Drum)							
Corrosion preventative	ANTICORIT G70 SPRAY	Multipurpose penetrating and dewatering anti-corrosion lubricant	Displaces and repels moisture	-	-	-	-	-	Convenient Ignition systems, Rusty bolts, Door hinges, Pully blocks.
		400 ML (Aerosol), 20 L (Spray)							
Corrosion preventative	ANTICORIT BW 366 & SPRAY	High-performance corrosion protection wax with a solvent. It produces a thick, touch resistant, long-term corrosion protection film.	M 3082 Type D2	M 3082 Type D2	-	-	-	-	It provides an excellent corrosion protection on semifinished parts, press-tools and moulds. Ideal for the long-term preservation of vehicles and equipment for the construction industry and for farming.
		400 ML (Aerosol), 5 L (Bucket), 20 L (Drum)							
Chain oil	AGRICENT SAW CHAIN	Mineral based lubricating oil blended from specially selected base oils, anti-wear and tackiness additives to make it suitable as a premium quality oil for use in agricultural chains, and other chain applications.	-	-	220	-	100	-5	The chain, chain sprockets and cutter bar on chain saws, as well as other chain applications.
		1 L (Bottle), 5 L (Bucket), 20 L (Drum), 210 L (Drum)							
White oils	CASSIDA FM WHITE OIL 15/46/68	Direct contact fluids for food processing applications in the food manufacturing industry	NSF 3H, H1 NSF ISO 21469 HALAL KOSHER	-	15/46/68	-	100	-10	General applications include manufacturing, packing, processing, preparing, treating and packaging food.
		20 L (Canister), 210 L (Drum)							
Compressor Oils	RENOLIN VAC PUMP 32 100	Specially formulated from selected paraffinic base oils which have been carefully refined to give very high oxidation stability and contain corrosion inhibitors and anti-oxidants.	-	-	32/100	5/11	95/101	-6/-7	Vacuum pumps operating under various conditions.
		5 L (Bottle), 20 L (Canister)							







Category	Product name	Description	Specifications	Main application area
Miscellaneous				
Cleaners	FUCHS BIO CLEAN	A solvent free, readily biodegradable, environmentally friendly water based heavy duty cleaner concentration which is sold as a concentrate. Which can be used within a food and pharmaceutical processing facility.	NSF A1 HALAL KOSHER	General degreasing Light cleaning - Bio Clean 5% : Water 95%. Medium cleaning - Bio Clean 10% : Water 90%. Medium High cleaning - Bio Clean 15% : Water 85%. Heavy grime and grease cleaning - Bio clean 35% to 100% : Balance water
  	1 L (Bottle), 5 L (Bucket), 20 L (Drum), 210 L (Drum), 1000 L (IBC FB)			
Cleaners	FUCHS BIO CLEAN PREMIX	A solvent free, readily biodegradable, environmentally friendly water based heavy duty cleaner that is READY TO USE and can be used within a food and pharmaceutical processing facility.	NSF A1 HALAL KOSHER	For normal cleaning apply Bio-Clean by spray, brush or mop and allow to stand for about 10 minutes, rinse off with water. For heavily soiled surfaces it is best to use some form of mechanical force before rinsing off with water. Apply and test the product on a small area before using, as it can stain certain painted surface.
  	1 L (Bottle), 5 L (Bottle), 20 L (Canister), 210 L (Drum), 1000 L (IBC FB)			
Cleaners	RENOCLEAN BIO HD	A solvent free, readily biodegradable, environmentally friendly water based heavy duty cleaner concentration.		For both commercial and industrial cleaning, works especially well on greasy surfaces. It can be used diluted or in its concentrated form without significant loss of cleaning power
	20 L (Canister)			
Cleaners	TITAN ENGINE CLEANER	Hydrocarbon and emulsifier blend, heavy duty cleaner, easily washed away with water after cleaning and degreasing of automotive parts.	-	For cleaning large parts on site allow sufficient time for the product to penetrate the dirt, mechanical assistance with a stiff brush can be helpful.
 	500 ML (Bottle), 5 L (Bottle), 20 L (Canister), 210 L (Drum)			
Cleaners	RENOCLEAN GRIT HAND CLEANER	Is a paste texture hand cleaner with very active cleaning properties. Formulated with the finest pharmaceutical and cosmetic ingredients which includes certain selected abrasives that are not harmful to the hands, as well as sophisticated emollients to avoid drying out of the hands.	-	The soap is ready to use in its concentrated form. Apply a small quantity on your hands and lather. Can be wiped or rinsed with water after cleaning. Should the hands be heavily soiled, repeated application might be necessary.
	500 G (Tub), 5 KG (Tub), 25 KG (Bucket)			
Miscellaneous	TITAN VALVE EASE	Fuel additive, containing special additives to clean gum and sludge from valves, pistons, rings, and carburetors.	-	Add one bottle of 200 ml MAINTAIN VALVE EASE to the petrol or diesel tank. 200 ml of MAINTAIN VALVE EASE treats 75 litres of fuel (375 : 1)
	200 ML (Bottle)			
Miscellaneous	CALIBRATION CENT/AD FLUID	Calibrating fluid for the fuel delivery system of diesel injection equipment. Controlled blending of distillates ensures viscosity and density to remain within narrow limits.		Calibration of diesel injector equipment.
 	20 L (Canister), 210 L (Drum)			
Miscellaneous	TITAN ADBLUE ®	Exhaust Emission Reduction Agent	DIN V 70070 ISO 22241-1 AUS32 CEFIC	AdBlue® is a harmless synthetic solution which is used as an exhaust emission reduction agent according to EGR1/DPF2/SCR3 technologies in heavy and some light vehicles with Euro 4*, Euro 5** i Euro 6*** diesel aggregates. AdBlue® is not a diesel additive.
 	5 L (Bottle), 20 L (Canister), 210 L (Drum)			





Service Products

Category	Product name	Description	Specifications	Approvals	Recommendations
Coolants / Anti-freeze					
Antifreeze	*FRICOFIN DP	Premium Performance Coolant Concentrate based on mono-ethylene glycol. Free of nitrites, amines and phosphates with Si-OAT-technology. Product dyeing: pink-violet.	AFNOR NF R 15-601 TYPE 1 AS/NZS 2108:2004 TYPE A ASTM D 3306 TYPE I ASTM D 4985 BS 6580:2010 SAE J814 CUMMINS CES 14603	DEUTZ DQC CC-14 MAN 324 TYPE Si-OAT MB-APPROVAL 325.5 MB-APPROVAL 325.6	DETROIT DIESEL 93K217 SCANIA TB 1451 VW TL 774-G (G12++)
  	20 L (Canister), 205 L (Drum), 1000 L (IBC FB)				
Antifreeze	*FRICOFIN DP 50	Premium Performance Coolant (READY TO USE) premix based on mono-ethylene glycol. Free of nitrites, amines and phosphates with Si-OAT-technology. Product dyeing: pink-violet.	AFNOR NF R 15-601 TYPE 3 ASTM D 3306 TYPE III ASTM D 4985 BS 6580:2010 SAE J814 CUMMINS CES 14603	DEUTZ DQC CC-14 MB-APPROVAL 326.5 MB-APPROVAL 326.6 VW TL 774-G (G12++)	DETROIT DIESEL 93K217 MAN 324 TYPE Si-OAT SCANIA TB 1451
  	20 L (Canister), 205 L (Drum), 1000 L (IBC FB)				
Antifreeze	FRICOFIN LL	An antifreeze Coolant Concentrate based on mono ethylene glycol and is used for engines in Heavy Duty vehicles, passenger cars and stationary machines. As OAT-Coolant Concentrate it provides a stable inhibitor system made of organic acids with highest change intervals. MAINTAIN FRICOFIN LL is free from nitrites, amines, phosphates and silicates.	ASTM D 3306 TYPE I ASTM D 6210 TYPE I-FF BS 6580:2010 SAE J814 FORD-WSS-M97-B44-D JAGUAR LAND ROVER STJLR.651.5003 FVV Heft R443 KSM 2142 UNE 26-361-88/1	Bez.Reg.Arnsbg. E62.12.22.64-2011-1 CAT / MWM TR 0199-99-2091 DAF 74002 DEUTZ DQC CB-14 MAN 324 TYPE SNF MB-APPROVAL 325.3 MTU MTL 5048	AFNOR NFR 15-601 TYPE I AS/NZS 2108:2004 TYPE A ASTM D 4985 SAE J1034 ADE (ATLANTIS DIESEL ENGINES) BAIC GROUP FOTON Q-FPT 2313005-2013 CATERPILLAR MAK A4.05.09.01 CHRYSLER MS 12106 CNH MAT 3624 CUMMINS (ISBe Motors of DAF and Leyland) CUMMINS CES 14603, CES 14439 DETROIT DIESEL 93K217 FIAT 9.55523 GM GMW 3420 (6277M)/GME L1301 HYUNDAI MS 591-08 JASO M325 JIS K2234 JOHN DEERE JDM H5 KOMATSU AF-NAC (07.892 (2009)) LIEBHERR MD 1-36-130 MACK 014 GS 17009 MAZDA MEZ MN 121 D PSA B 71 5110 RENAULT 41-01-001/- -S Type D Bergen Engines 2.13.01 SAAB B 040 1065 SKODA 61-0-0257 TOYOTA TSK 2601G-8A VW TL 774-D/F (G12+ / different colour) VOLVO COOLANT VCS (STD 418-0001)
 	20 L (Canister), 210 L (Drum)				

Category	Product name	Description	Specifications	Approvals	Recommendations
Coolants / Anti-freeze					
Antifreeze	FRICOFIN LL 50	A coolant ready-mix based on monoethylene glycol and demineralized water for commercial vehicle and passenger car engines as well as stationary installed combustion engines. As a premixed OAT antifreeze, it provides a stable inhibitor system made of organic acids with highest change intervals. MAINTAIN FRICOFIN LL 50 is free from nitrites, amines, phosphates and silicates.	ASTM D 3306 TYPE III ASTM D 6210 TYPE III-FF BS 6580:2010	CAT / MWM TR 0199-99-2091 DAF 74002 DEUTZ DQC CB-14 MAN 324 TYPE SNF MB-APPROVAL 326.3	ASTM D 4985 SAE J1034 Bez.Reg.Arnsbg. E62.12.22.64-2011-1 CATERPILLAR MAK A4.05.09.01 CHRYSLER MS 12106 CNH MAT 3624 CUMMINS CES 14603, CES 14439 DETROIT DIESEL 93K217 FIAT 9.55523 FORD WSS-M97-B44-D2 GM GMW 3420 (6277M) HYUNDAI MS 591-08 JAGUAR LAND ROVER STJLR.651.5003 JOHN DEERE JDM H5 KOMATSU AF-NAC (ready mix) (07.892 (2009)) LIEBHERR MD 1-36-130 MACK 014 GS 17009 MAZDA MEZ MN 121 D PSA B 71 5110 RENAULT 41-01-001/- -S Type D SAAB B 040 1065 SKODA 61-0-0257 TOYOTA TSK 2601G-8A VAUXHALL GME L1301 VOLVO COOLANT VCS (STD 418-0001) VW TL 774-D/F (G12+ / different colour)
  	1 L / 5 L (Bottle), 20 L (Canister), 210 L (Drum), 1000 L (IBC FB)				
Antifreeze	FRICOFIN JF	A concentrate antifreeze coolant based on Monoethylene Glycol. It is formulated with the additive composition that meets the requirements of modern cooling systems.			ASTM D 3306 BS 6580 SANS 1251:2005
 	1 L / 5 L (Bottle), 20 L (Canister), 210 L (Drum)				
Antifreeze	FRICOFIN JF 50	A ready to use antifreeze coolant based on Monoethylene Glycol and demineralized water, formulated to meet the requirements of modern cooling systems.			
 	1 L / 5 L (Bottle), 20 L (Canister), 210 L (Drum)				

Motorcycle/ off road vehicles - Silkolene range

Product name	Description	Specifications	Approvals	FUCHS Recommendations
2 Stroke				
SILKOLENE COMP 2 PLUS	Fully synthetic, ultra-low smoke 2-Stroke engine oil for high performance motorcycles	JASO FC / FD ISO L-EGD API TC		
	1 L (Bottle)			
SILKOLENE PRO 2	Ultimate Fully Synthetic Ester 2-Stroke Premix engine oil	SILKOLENE PRO 2 meets the stringent test requirements of the CIK-FIA (COMMISSION INTERNATIONALE DE KARTING - FEDERATION INTERNATIONALE DE L'AUTOMOBILE) and is a CIK-FIA approved (homologated) lubricant.		
	1 L (Bottle)			
Engine Oil				
SILKOLENE SUPER 4 RANGE	Semi-synthetic 4-stroke engine oil for modern motorcycles	SILKOLENE SUPER 4 10W-40 JASO MA2 API SL SILKOLENE SUPER 4 20W-50 JASO MA2 API SF / SG Performance		
	1 L (Bottle)			
SILKOLENE QUAD ATV 5W-40/10W-40	Fully synthetic 4-Stroke oil for modern highly stressed Quads and ATVs	API SN ACEA A3/B3 JASO MA2		
	1 L (Bottle)			
Coolant				
SILKOLENE PRO COOL	Advanced all season reduced toxicity engine coolant			
	1 L (Bottle)			
Gear Oil				
SILKOLENE COMP GEAR	Synthetic Ester technology racing gear oil			
	1 L (Bottle)			
SILKOLENE PRO 4 XP RANGE	Extreme Performance Semi-Synthetic Ester Engine oils	JASO MA2 API SL Performance		
	1 L (Bottle)			

Product name	Description	Specifications	Approvals	FUCHS Recommendations
Chain Lube				
SILKOLENE TITANIUM DRY LUBE	SILKOLENE TITANIUM DRY LUBE is formulated with a hyper strong PTFE and Titanium boosted formula to provide exceptional antiwear performance while providing excellent high speed fling off resistance. The solid lubricant inclusions provide outstanding boundary lubrication and friction reduction. Special additives also give maximum corrosion protection even in the most severe weather conditions			
	500 ML (Bottle)			
SILKOLENE CHAIN LUBE	Synthetic technology motorcycle chain lubricant			
	500 ML (Bottle)			
Brake Fluid				
SILKOLENE BRAKE FLUID	Brake fluids are often forgotten but are possibly the most essential fluid in a vehicle from the safety aspect. They need checking and changing regularly to avoid brake fade and loss of efficiency.	SILKOLENE UNIVERSAL BRAKE & CLUTCH FLUID meets the requirements of earlier specifications SAE 70R 1 and 3 SAE J70C SAE J1703 A to F. Mixes safely with all fluids meeting the current standards FMVSS116 DOT 5.1 DOT 4 DOT 3 ISO 4925 SAE J 1703. Wet Boiling Point Min: 155°C (311°F) Initial Boiling Point Min: 230°C (446°F) DOT 4		
	500 ML (Bottle)			
Filter Oil				
SILKOLENE FOAM FILTER OIL	SILKOLENE FOAM FILTER OIL is a technologically advanced coating treatment designed to improve the efficiency of foam air filters. The product contains polymeric additives which provide a hyper-tacky surface which resists the ingress of the most pervasive sand, dust and water without affecting engine breathing.			
	500 ML (Bottle), 1 L (Bottle)			
Cleaner				
SILKOLENE WASH OFF	A cost-effective spray-on / hose-off bike cleaner			
	1 L (Bottle)			

FUCHS LUBRICANTS

Innovative lubricants need experienced application engineers

Every lubricant change should be preceded by expert consultation on the application in question. Only then the best lubricant system can be selected. Experienced FUCHS employees will be glad to advise on products for the application in question and also on our full range of lubricants.

FUCHS Oil Chooser: www.fuchs.com/za-en

Find the right oil for your vehicle.



It's so simple: at www.fuchs.com/za-en just go to the button "Oil Chooser". Then select the type of vehicle and hereupon make and model.

Contact:

