

PRODUCT INFORMATION

EASI-MIX PREMIUM COMPACT SYSTEM

MOVING YOUR WORLD



EASI-MIX PREMIUM

The Easi-Mix Premium System is available in many shapes and sizes which is why we have the flexibility to meet your requirements. The systems are designed and built to suit what the customer needs.

- The standard units are built in Sheffield
- To deliver up to 50lpm at 4.5 bar
- Holds 250ltrs of water following the AGAP water regulations.
- Can mix accurate concentrations from 1% up to 99% on mineral or synthetic oils.
- Can be supplied with trigger gun nozzle and connected to a ring main. HMI touch screen controls
- Pressure Sensors for dry running protection of oil and water supplies
- 230v 16 Amp Supply required

Options Available

- Visual alarms and reminders for operators on screen
- Remote monitoring of fluid levels and volumes used.
- PH level and temperature probes
- Cloud based Integration facility



EASI-MIX SYSTEMS

COOLANT SUSTAINABILITY

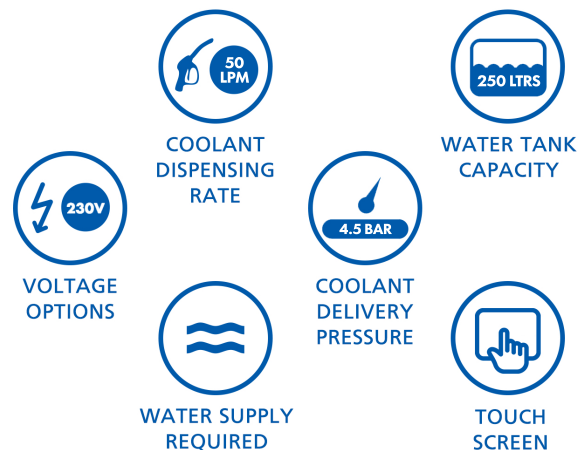
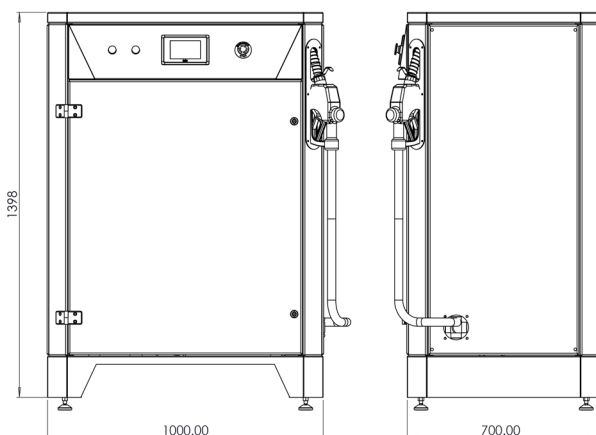

FUCHS LUBRICANTS (UK) plc
New Century Street, Hanley,
Stoke on Trent, ST1 5HU
Telephone: +44 (0)1782 203700
E-Mail: contact-uk@fuchs.com
www.fuchs.com/uk

[/fuchslubricantsuk](https://www.facebook.com/fuchslubricantsuk) [@fuchslube_uk](https://twitter.com/fuchslube_uk) [/fuchs-lubricants-uk-plc](https://www.linkedin.com/company/fuchs-lubricants-uk-plc)